



## System Specifications

### Intended Environment:

- Multi-level parking garages
- Structures are typically concrete with open apertures
- Rainwater and road salting agents common in northern climates

**Fixture Type:** Linear Fluorescent

**Lamp Configuration:** 48 inch / 3-Lamp T8 / 32W / Electronic Program / Rapid Start Ballast

**Voltage:** 120/277 VAC, 50/60 Hz

**Environment:** UL Recognized and IP 65 Rated  
Operating Temperature: -30° C to +70° C

### Electrical:

#### Lamps:

- 32 Watts
- 3100 Initial Lumens
- Color Index 80
- Color Temp. 5000K

#### Dual Ballast:

- Dual Lamps (2), Upper
- Single Lamp, Low Center
- GE UltraStart: High Ballast Factor

Radio: FCC Part 15.247 (2400-2483.5MHz)

### Product Design Ratings:

**Lamps:** 42,000 hours at 12 hour starts

**Ballasts:** 100,000 hours

**Radio Control:** 100,000 hours

### Manufacturer's Warranty:

**Lamps:** 16,000 hours

**Ballasts:** 5 years

**Radio Control:** 10 years

**Fixture Housing:** 5 years



## System Specifications (continued)

### Cross Section and Photometry:

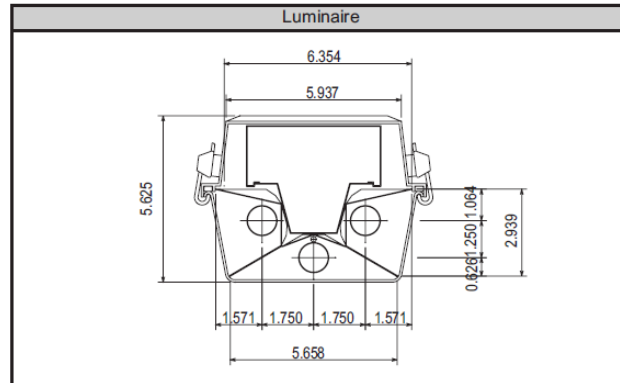

Cross Section (inches)

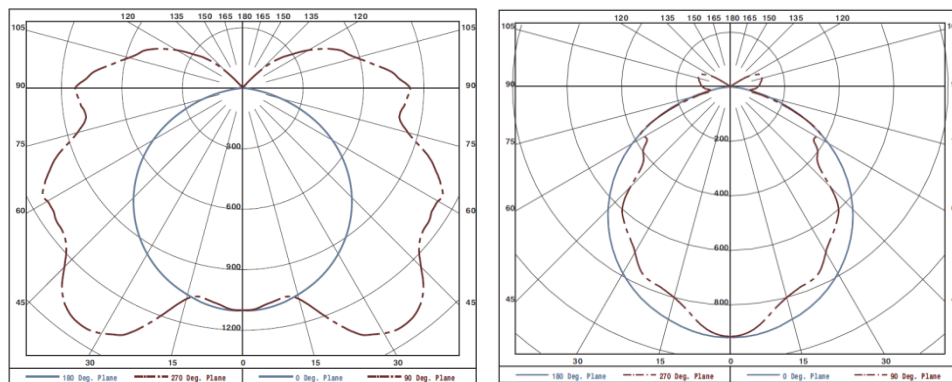

Three Lamp State

One Lamp State

### Additional Specifications:

- Housing:** Constant seal gasketed fiberglass enclosure. Dust free and moisture resistant.
- Reflector:** Custom slot design, Micro4® enhanced specular aluminum with a total reflectivity of 95%.
- Mounting:** Suitable for surface or pendant mounting. Slotted steel brackets and pre-wired whips.
- Lampholders:** Lamps are secured with Leviton locking lampholders.